

# ELECTRIC PALLET TRUCK EPT-2 x 500



## *USER'S MANUAL*



**Edition: May 2014**



---

# ***USER'S MANUAL***

## INDEX

---

1. MAIN COMPONENTS	1.1
2. SAFETY INSTRUCTIONS	2.1
3. CONTROL SWITCHES AND INDICATORS	3.1
4. SWITCH ON AND WORK	4.1
5. LOADING AND UNLOADING	5.1
6. SERVICE AND CARE	6.1
7. LONG WAREHOUSING	7.1
8. TECHNICAL SPECIFICATIONS	8.1

---

# 1. MAIN COMPONENTS

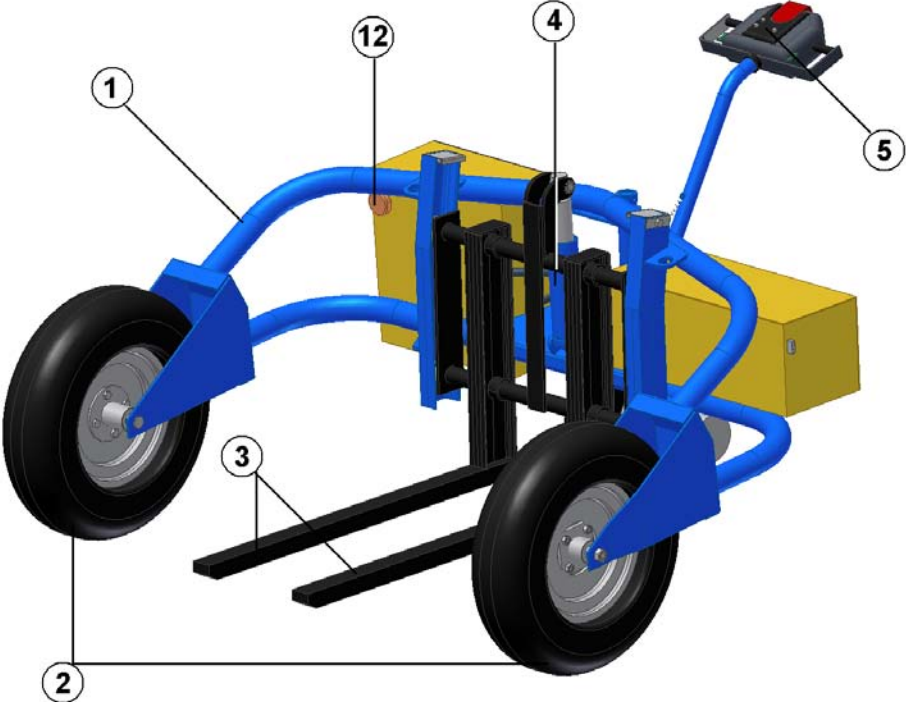

- ① Chassis
- ② Front wheels
- ③ Fork grouping
- ④ Hydraulic cylinder
- ⑤ Handle
- ⑥ Motor drive wheel
- ⑦ Hydraulic motor pump
- ⑧ Electronic controller
- ⑨ Electric braking
- ⑩ Batteries
- ⑪ Load indicator
- ⑫ Horn
- ⑬ Emergency Stop

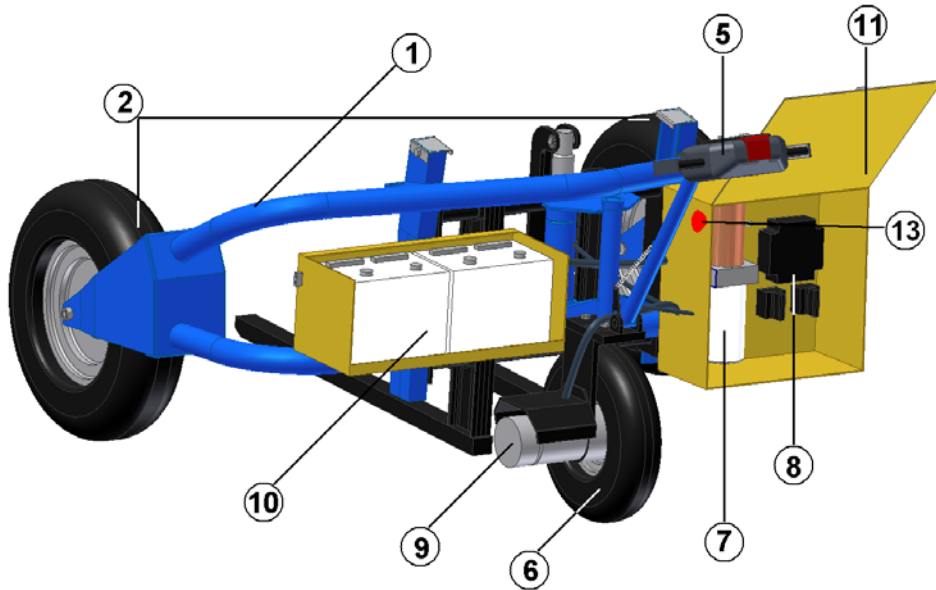

- ① Chassis
- ② Front wheels
- ③ Fork grouping
- ④ Hydraulic cylinder
- ⑤ Handle
- ⑥ Motor drive wheel x2
- ⑦ Hydraulic motor pump
- ⑧ Electronic controller
- ⑨ Electric braking
- ⑩ Batteries
- ⑪ Load indicator
- ⑫ Horn
- ⑬ Emergency stop



## **2. SAFETY INSTRUCTIONS**

Etiquettes	2.2
Hand pallet truck safety	2.4
Daily inspections	2.5
Hand pallet truck operator	2.9
Movement in ramps and special areas	2.10
Transport of the pallet truck	2.12
Testing	2.13
Noise level	2.13
Dangerous environment	2.13

## ETIQUETTES

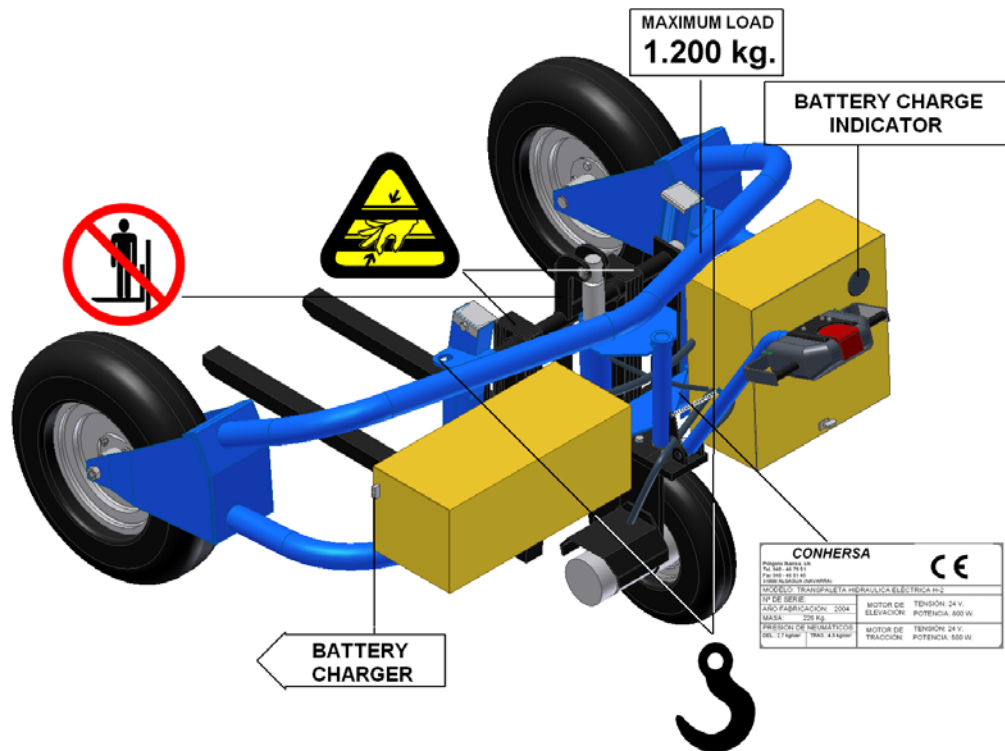





**WARNING**

**Do not stand on the forks.**



**WARNING**

**Keep hands, feet and body away from masts and forks. Danger of trapping between fix and mobile parts.**

---

**CAUTIONS WHILE LOADING BATTERIES**

1. Load batteries at an open-air area, away from flames, fumes and sparks. Battery's gasses may be explosives
2. Do not smoke around the loading area.
3. Do not switch off during loading: danger of sparks.

## **HAND PALLET TRUCK SAFETY**

---

### **USE UNDER INSTRUCTIONS**

Hand pallet truck may only be used under instructions included in this manual.



### **WARNING**

This hand pallet truck may only be used to transport palletised materials.

### **WARNING**

Should you wish to use it for different purposes, you may ask for CONHERSA'S agreement and, if necessary, your local authorities in order to avoid risks.



### **WARNING**

In case of handle malfunction, press emergency stop button, switch off and contact our technical service.

## **DAILY INSPECTIONS**

Before using, following inspections shall be followed:

1. Brake: When releasing handle, make sure that hand pallet truck is restrained and you can not move it.
2. Forks: Visual inspection. Verify correct lift and descent. No damage in forks.
3. Hydraulic circuit: Verify possible looses (leaks) in pipe and cylinder.
4. Wheels: Verify tyres state. Tighten bolts. Verify wheels pressure.
5. Control instruments: Switch on key. Verify battery's light indicators lights on.
6. Battery: Correct charge level (one green light minimum).
7. Horn: Verify well function.
8. Lifting: With forks unloaded, verify correct lifting and descent.
9. Connected: Verify movement forward and reverse.

## **WARNING**

**In case of malfunction, switch off, inform to whom it may concern, and contact technical service.**

---

### **BRAKE**

When releasing handle, verify that speed controller returns to neutral position and brake is immediately blocked. (When blocking, a sound must be noticed).

Push the pallet truck to make sure that it is well blocked and you can not move it.

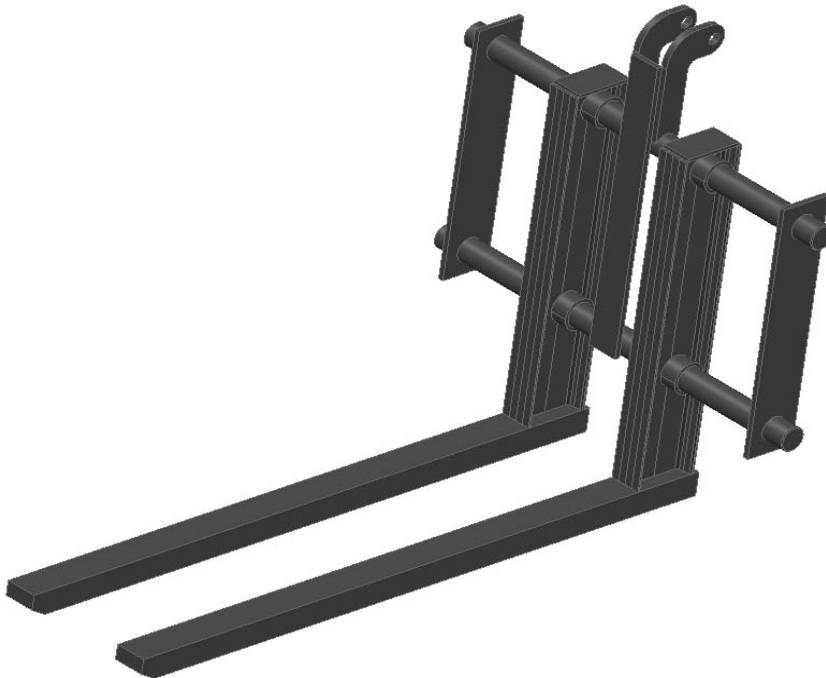

---

## FORKS

Lift the fork by hand and place it where needed.

Forks must be placed in symmetry as per the axle.

The own friction of the forks avoid of not intended displacement.

---

## HYDRAULIC CIRCUIT

Verify oil level in the deposit.

Verify in case of possible oil losses (leaks).

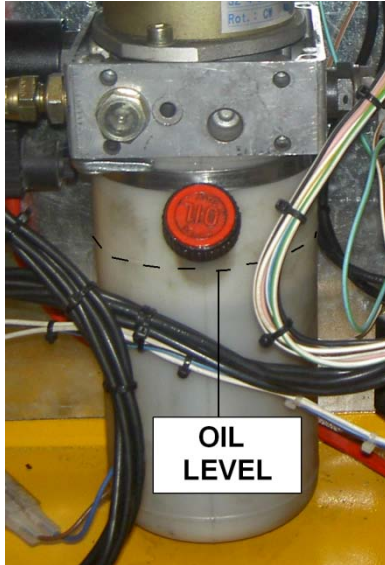

---

## WHEELS

	FRONT	REAR
Measure	155R13"	4.00-8
Pressure	2,7 bar	Solid



front



rear

---

## BATTERY CHARGE LEVEL

Turn the key to ON position.

Verify charge level in the indicator. If level is under 20% (last red left spot) you will not be able to use the pallet truck. Connect the charger for approximately 10 hours (See procedure on page 5.1).



---

## CONTROL INSTRUMENTS AND Horn

Turn on the key. Verify battery  
light indicator is on



Verify horn by pressing the horn  
button.

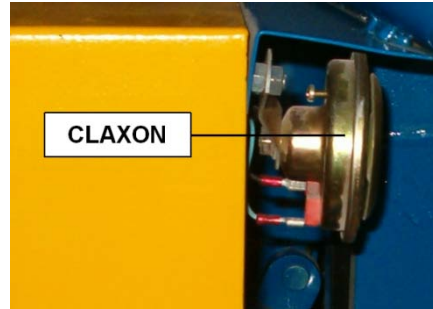

---

## HANDLE

Unloaded, press lifting and  
descending buttons to verify that  
forks go up and down correctly.

Press smoothly the forward-  
reverse switch and verify that the  
blocked brake is self-released (an  
audible sound is heard), and the  
truck commences to move gently.

Verify both, forward and reverse.

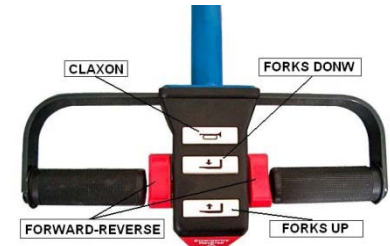

# HAND PALLET TRUCK OPERATOR

## USER'S KNOWLEDGE

### WARNING

While using, this manual's instructions shall be observed, as well as local/national legal dispositions.

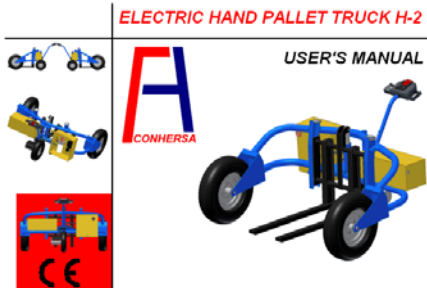

## SAFETY CLOTHING

Each site's observations should also be observed while using the pallet truck.

For example:



HELMET



HEARING PROTECTOR



GLASSES



COVERALL



GLOVES



MASK



SAFETY FOOT WEAR

### WARNING

For clothing, observation of the national rules and obligations is as must.

**Clothes should be tight enough to avoid traps. If necessary in the working site, user should also wear protective glasses, helmet, gloves, and whatever required.**

## **MOVEMENT IN RAMPS AND SPECIAL AREAS**

### **WARNING**

Using the electric rough terrain hand pallet truck for transporting goods in ramps is strictly forbidden.

Only permitted with the pallet truck unloaded, if necessary.

### **WARNING**

Do not turn in ramps. Movement in ramps is delicate: pay maximum attention and care.

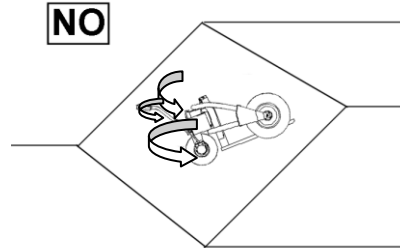

### **WARNING**

Caution when moving on a truck surface. Please make sure that the truck is stopped.

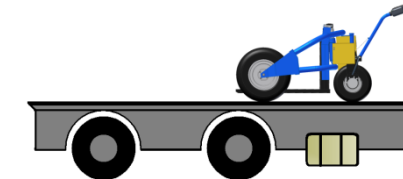

The ramp used to place the hand pallet truck onto the truck must be resistant enough to bear the hand pallet truck.

Ramp should be firmly placed on the ground in order to avoid unexpected movements.

Pay maximum attention during the loading and unloading of the hand pallet truck on the truck.



---

## ENTRY IN SERVICE LIFTS

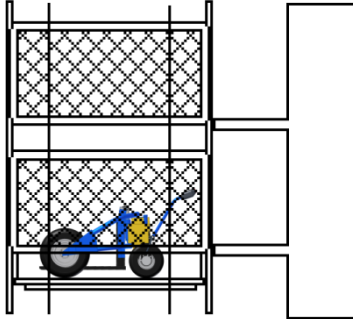

Elevation of the pallet trucks in service lifts should only occur when the service lift has enough power and has been designed for this purpose.

Make sure that the pallet truck does not touch the sides of the service lift, and that it is well placed in order to avoid unexpected movements. Operators should never get into the service lift before the pallet truck. Get out of the lift always before the pallet truck.

## WARNING

**Make sure that the service lift is powerful enough –see the service lift weight capacity- to load the pallet truck.**

**Do not operate nor work with the pallet truck inside the service lift.**

---

## MOVEMENT

### *Visibility*

Do not drive forward when the load does not permit complete visibility. In that case, drive backward, except when driving into a service lift, where entering backwards is forbidden.

If visibility difficulties remain, another operator should indicate the correct direction. In this case, drive slowly and handle with care.

Verify that working area is lightened enough.

## **TRANSPORT OF THE PALLET TRUCK**

### **WARNING**

1. Unloaded, put forks in the upper position.
2. Confirm that in and out angles do not interfere with the ground or transport platform. (see picture)
3. When using a wooden made bridge between platform and dock, make sure that the planks can bear the pallet truck.
4. Use only the lifting hangers to lift the pallet truck. (see picture)
6. Switch off and release contact key.

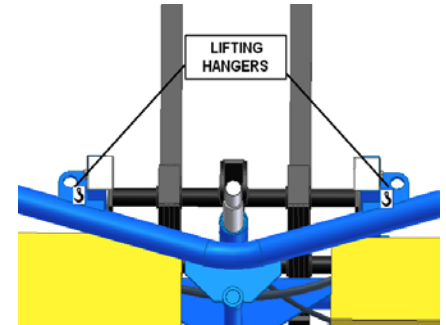
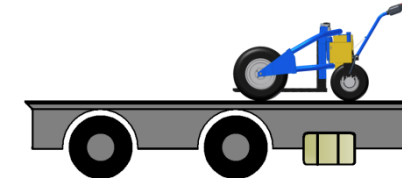
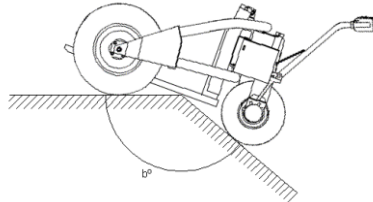
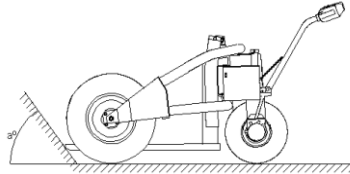

## **TESTING**

After transport or a long warehousing period, functional testing is necessary.

Three tests:

1. Daily inspection test. (See page 2.5), to be made by users.
2. Dynamic tests, to be made by the technical service.

### **2.1. Movement test.**

Confirm that the pallet truck moves towards the correct forward-reverse switch, and confirm that the blocking brake works properly.

With the pallet truck loaded, press up and down buttons to make sure of correct work.

### **2.2. Piling test.**

Lift completely and descent the load at maximum speed several times.

### **2.3. Descending speed test.**

Confirm that descending speed is not more than 0.6 m/s.

## **NOISE LEVEL**

NOISE LEVEL
Less than 70 dB (A)

## **DANGEROUS ENVIRONMENT**

### **WARNING**

**Use of pallet truck in dangerous environment is strictly forbidden.**

**A dangerous environment may cause fire or explosions because of dust, fumes or gasses.**

### 3. CONTROL SWITCHES AND INDICATORS

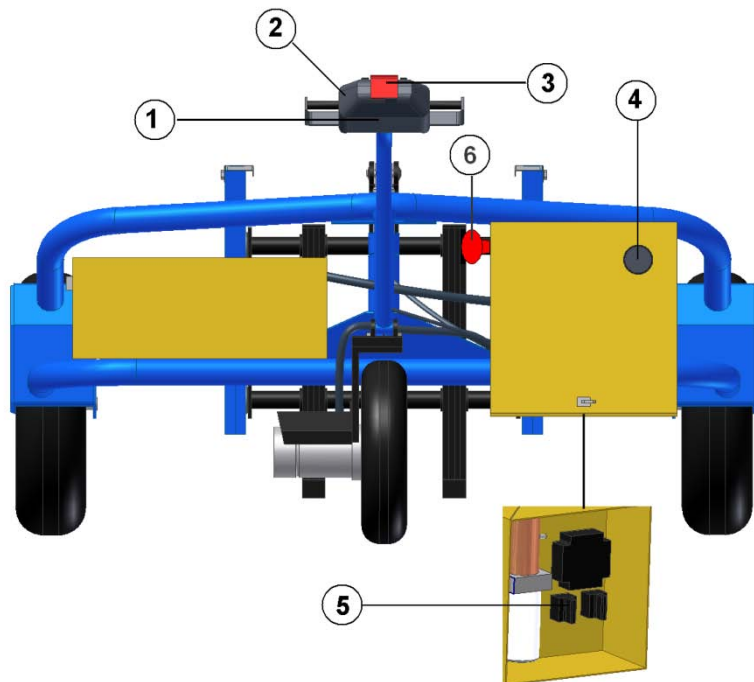

- ① Contact key.
- ② Handle.
- ③ Belly button.
- ④ Battery charge indicator.
- ⑤ Fuses
- ⑥ Emergency Stop

---

## HANDLE SWITCHES

### *Contact key*

Contact key is located at the lower part of the handle.

It has two positions:

- Connected
- Disconnected

When connected, the batteries light indicator will turn on.

When disconnected, all circuits are off.

### *Forward-reverse switch.*

It is the green switch. It may be pressed either with the left or the right hand.

When releasing, it comes back to the neutral position.

### *Buttons for lifting and descending the forks.*

They are located at the right hand side of the handle.

When pressing, the forks start to move, and they stop just when buttons are released.

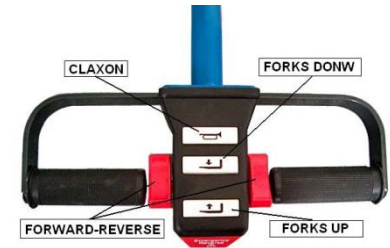

---

## CONTROL INDICATORS

### *Claxon*

The claxon is located at the right hand side of the handle.

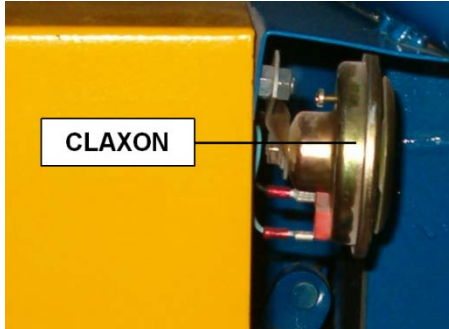

### *Battery charge level indicator*

It has five levels. First in red, second in yellow, and other three in green.

Three things to know:

1. When turning the key on, lights should light on, indicating that the pallet truck is ready to be used.

2. The number of lights on indicates the battery charge level.

3. If the level is under 20% (only red light on), the traction motor is automatically turned off. You will only be able to put the load down.



### *Fuses*

The fuses are located in the electronic control.

## WARNING

**The fuses may only be changed by the specialized personnel.**

**Replace the fuses by others with similar characteristics.**

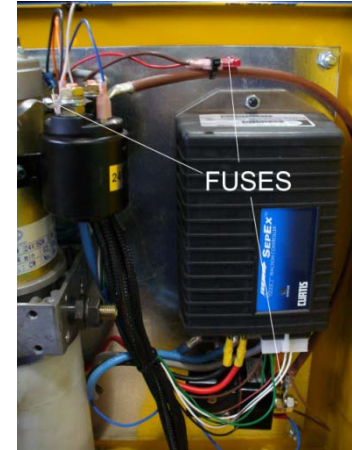

## WARNING

**When the pallet truck is not being used, make sure to turn it off.**



## 4. SWITCH ON AND WORK

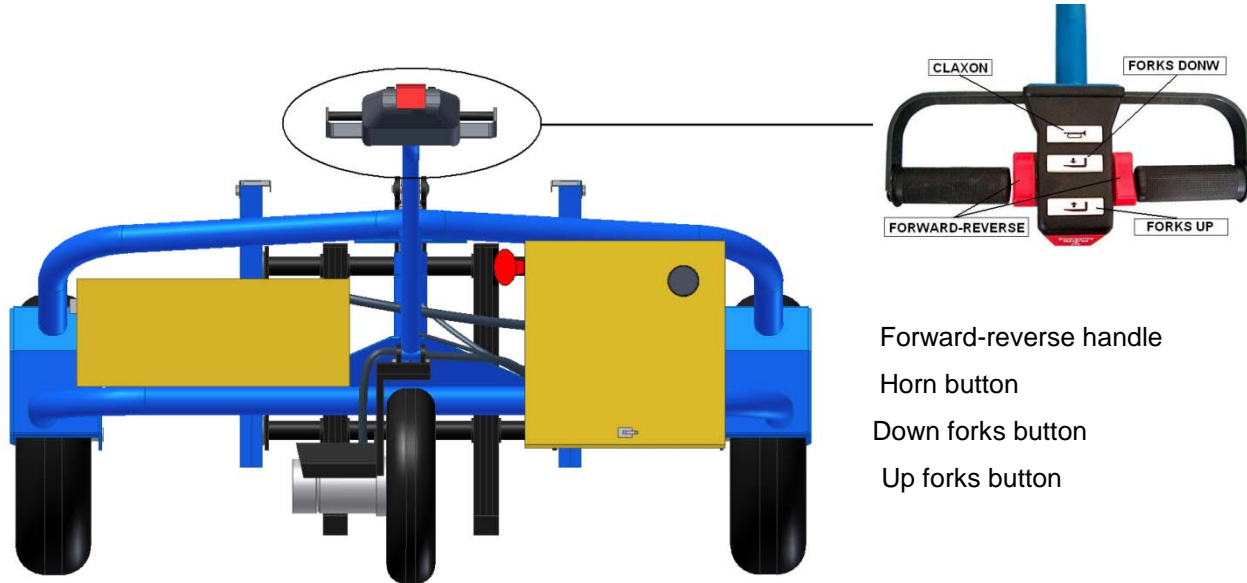



---

## SWITCH ON AND WORK

### WARNING

**Before using the pallet truck, please read carefully all the security instructions of this user's manual, pages 2.2 to 2.13 of this manual.**

1. Confirm that the blocking brake is on by pushing the pallet truck: you should not be able to move it.
2. Disconnect the emergency stop
3. Turn on the key without pressing the throttle.

### WARNING

**If the blocking brake does not work, do not turn on the key.**

4. Make sure that there is enough battery charge by checking the indicator.
5. Confirm that your way is clear, and press the dead-man function, and the forward-reverse throttle smoothly towards the required way.

#### *Movement*

While moving, the forks must be at their top position.

#### *Turn*

The closer you turn, the slower the speed should be, in order to avoid unexpected load movements.

#### *Movement on slopes (ramps)*

**Movement on slopes with the machine loaded is strictly forbidden.**

### WARNING

**When leaving the pallet truck, put down the forks and remove the contact key.**

**If error "CODE 23" appears, two causes:**

1. Forward-reverse throttle has been pressed without using the dead-man function, or
2. the temperature thermal switch of the motor has reached and excessive heating, due to an intensive work. Turning off the machine during 20 minutes should be enough to cool the machine.

## **5. LOADING AND UNLOADING**

---

### **LOADING**

Adjust the forks in symmetry as per the pallet truck axle. The more separated the forks are, the more stability there is.

Face the load frontally and stop just before. Adjust forks height to enter into the pallet to be loaded correctly.

Move forward smoothly under the pallet, and when stopping, make sure that the blocking brake is automatically activated (blocking sound should be noticed)

Lift the load. Make sure it remains stable. Press forward or reverse and move slowly.

---

### **TRANSPORT**

Moving with the pallet truck loaded should be made with special care and attention. If the load height does not allow proper visibility, the pallet truck must be driven forward, except when entering into the service lifts, where it is strictly forbidden.

---

### **UNLOADING**

Move towards the unloading area slowly.

Verify that, when stopping, the automatic blocking brake is on (blocking sound).

Put down the forks to unload.

Move reverse to get away from the pallet.

When restarting again, make sure that the forks are in the top position to avoid any obstacle while moving.



## **6. SERVICE AND CARE**

Classification of maintenance works	6.2
Maintenance to be made by the technical service	6.2
Maintenance to be made by users	6.3

## **CLASSIFICATION OF MAINTENANCE WORKS**

There are two types of maintenance works:

1. Technical service: Only to be made by the technical service.
2. User: To be made by the pallet truck users (qualified worker)

### **WARNING**

**User should not make any reparations nor maintenance when technical service is required.**

**Some operations may be dangerous and should only be made by the technical service.**

## **MAINTENANCE TO BE MADE BY THE TECHNICAL SERVICE**

The following operations should **only** be made by our technical service:

1. Batteries condition control.
2. Change batteries.
3. Change hydraulic oil.
4. Adjust motor pump.
5. Maintenance of the electronic control.
6. Change the rear tyre.
7. Change fuses.

## **MAINTENANCE TO BE MADE BY THE USER**

As well as the daily inspections (see page 2.5), the worker must carry on with the following:

1. Tyres air-pressure control.
2. Change the front tyres.
3. Charge batteries.
4. Pallet truck cleaning.
5. Emergency forks descent.

## **MAINTENANCE TO BE MADE BY THE USER**

### **WARNING**

Before making any maintenance, turn off the key.

Confirm that the automatic blocking brake is on.



## **TYRES AIR-PRESSURE CONTROL**

From time to time, the air-pressure control should be made to confirm that it is correct.

### *Front tyres*

1. Release valve screw-top.
2. Connect a manometer.
3. Correct pressure is 2,7 bar. If it is less, add air with the pump.

	Pressure (bar)
Front	2,7
Rear	Solid

## **CHANGE FRONT TYRES**

### *Front tyres*

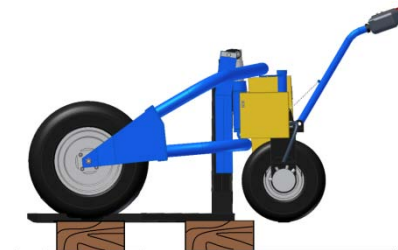

1. Put a wooden chock under the pallet truck to separate it from the floor. Verify that pallet truck remains stable.
2. Fasten the bolt with a wrench. With the other hand, loosen the nut with an 18 wrench, just up to when there are only few turns of the nut left.

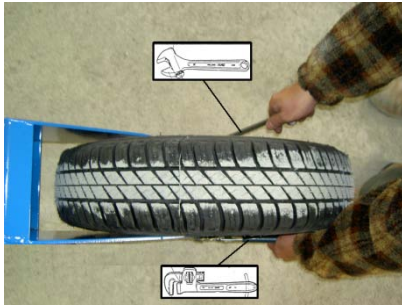

3. With a nylon hammer or wooden chock, hit the nut in order to take it out.
4. Unscrew completely the nut and release the bolt by hand.
5. Take out the wheel.
6. Once the wheels is taken out, repair the puncture, change the tyre, etc.
7. Assembling procedure should be done all the way round. Make sure not to damage the nut when inserting.

NOTE: Do not tight the nut too much: some pieces could be damaged and turning the pallet truck would be impossible.

*Rear tyre*

### **WARNING**

**The rear tyre has a double rim, and operations of assembling and dissembling requires the technical service.**



---

## BATTERY CHARGE

### WARNING

1. Charge the batteries in a well ventilated area, away from heating points and sparks. (Gases of batteries may be explosives)
2. Do not smoke in the charging area.
3. Do not disconnect the connector during the charging process: risk of sparks.

#### *Suggestions for the battery charge*

1. For a longer battery life, it should be discharged at least 35% before charging.
2. To avoid deep discharge that could cause lifeless, when arriving to a 20% of battery charge, the machine slows its speed drastically.



#### *Charging process*

1. Move pallet truck close to an electric socket (220 V).
2. Turn off the contact key.



3. Connect the provided cable to the pallet truck and an electric socket (220 V).
4. Verify that the red light is on.
5. Batteries are completely charged when the green light is permanent.
6. Disconnect the cable, wind it and keep it safe. .
7. Turn the contact key on and confirm that all the battery charge level is at 100%.



## BATTERIES MAINTENANCE

---



### WARNING

1. Batteries maintenance must be made by authorized personnel.
2. Always use gloves and protective glasses.
3. Smoking in the area is forbidden.

### *Maintenance frequency.*

Must be done at least twice a year (if possible, before and after summer).

6.6

1. Loosen with a screwdriver the 10 screws of the batteries yellow metal box.

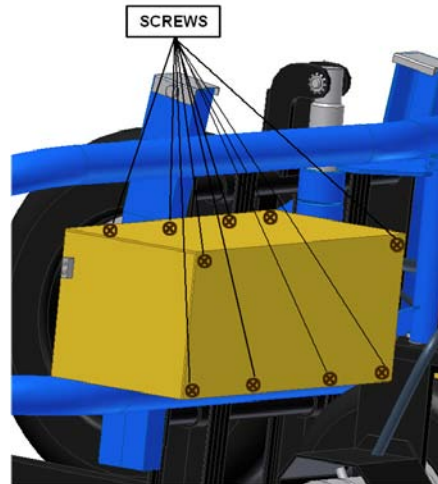

2. Take out the top and front part of the metal box.
3. Confirm that there are no electrolyte leaks and no corrosion on the tips.

4. Put aside the top of the battery glasses carefully, without touching the connecting tips.

5. Verify that the electrolyte level is correct. If necessary, fill in with distilled water up to the nets.

---

## CLEANING THE PALLET TRUCK

### WARNING

Before cleaning, turn off the key.

Verify that the blocking brake is on.

*Cleaning the handle.*



Clean the dust with a brush.

**Do not use water.**

Finish with a dry cloth.

*Cleaning the motor chassis*



Clean the dust with a brush.

**Do not use water.**

Finish with a dry cloth.

*Cleaning the forks grouping guides.*

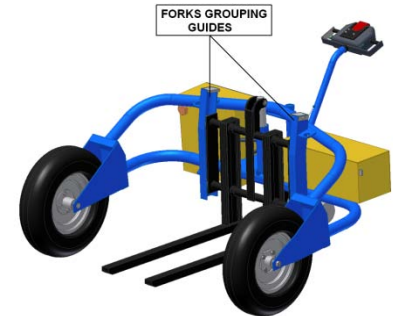

Clean the dust with a brush.

**Do not use water.**

Finish with a dry cloth.

---

## EMERGENCY DESCENT OF THE FORKS

If the forks are suddenly blocked in the top position, there is a way of putting them down:

1. Turn off the key.
2. Open the right hand side box, where the motor pump is located.
3. Verify that there are no obstacles under the forks.
4. Press the red button to make the forks go down.



## 7. LONG WAREHOUSING

---

### LONG TIME WAREHOUSING

When the pallet truck is not going to be used for a long time, keep it in a dry and clean place, and follow the following instructions:

1. Clean the pallet truck as explained before.
2. Charge the batteries completely.
3. Place the pallet truck in a horizontal position.
4. Disassemble the batteries and put them in a dry and fresh place.

Put the pallet truck on wooden sticks in order to avoid damages and deformations of the tyres.

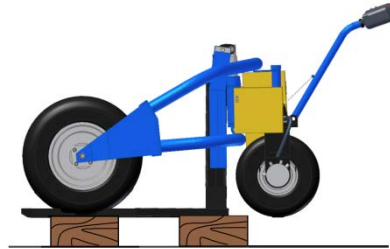

### WARNING

**When there is no inside area available, place the pallet truck in a horizontal area and cover it completely with a waterproof plastic cover.**

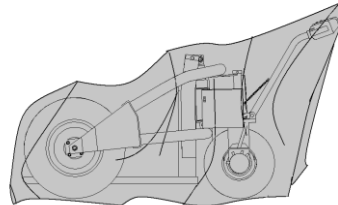

**For warehousing for a longer period, please contact technical service.**

### WARNING

**Don not use a waterproof cover made of vinyl: it may cause static electricity and subsequently produce flames with the batteries gasses.**

---

## SERVICE DURING THE WAREHOUSING

1. Charge batteries every two months.
2. Make visual inspections to verify that there is no corrosion.
3. Clean the dirty areas and apply anticorrosion if needed.

---

## POST-WAREHOUSING SERVICES

1. Remove the anticorrosion grease of the exposed areas of the hydraulic cylinders.
2. Charge the batteries completely.
3. Turn on the key to confirm batteries are completely charged
4. Go ahead with the tests of page 2.13

## 8. TECHNICAL SPECIFICATIONS

In this plaque, located at the right hand side, following information should be seen: Serial number, traction motor, elevation motor, tyres pressure, etc.

<b>CONHERSA</b>			
Poligono Ibarrea, s/n Tel. 948 - 46 79 51 Fax 948 - 46 81 45 31800 ALSASUA (NAVARRA)			
MODEL: ELECTRIC HAND PALLET TRUCK H-2			
SERIES Nº:	MOTOR	TENSIÓN: 24 V.	
MANUFACTURING YEAR: 2005	PUMP:	POWER: 800 W.	
MASS: 226 Kg.	TRACTION MOTOR: TENSIÓN: 24 V. POWER: 500 W.		
TYRES AIR-PRESSURE	FRONT: 2.7 kg/cm <sup>2</sup> REAR: SUPERELASTIC		

### MAIN PARAMETERS

MAXIMUM FORWARD-REVERSE SPEED	< 0,6 m/s
MAXIMUM LOAD PERMITTED	1.200 kg
MAXIMUM FORKS ELEVATION	200 mm

### WARNING

**Do not overload the pallet truck.**

**Do not try to exceed the above parameters.**